

www.smtcl.com

Corruption Reporting
Service Hotline

4006159999

SHENYANG MACHINE TOOL CO., LTD.

SHENYANG NO.1 MACHINE TOOL WORKS

No. 1, 17-A, Kaifa Avenue, Shenyang Economic & Technological
Development Zone, Shenyang, China

Postcode: 110141

Tel: 024-25191521

Fax: 024-25190641

After Service Tel: 024-25190141

After Service Fax: 024-25190625

E-mail: s1_sales@smtcl.com

http://www.smtcl.com

After Service President Monitoring Tel: 024-25656655



The explanation, diagram and technical parameter are varying with continuous technology development without further notice. (20140328-FT14002)

沈阳机床股份有限公司
中国沈阳经济技术开发区
电话: 400-001-3099

www.smtcl.com



T2C
T2Cm
T2S
T2Sm
T4C
T4Cm
T4S
T4Sm



VIVA TURN 2/4
CNC LATHE

SHENYANG MACHINE TOOL CO., LTD.

VIVA TURN 2/4

CNC LATHE

Thorough Upgradation We Can Redefine The CNC Lathe

Viva Turn 2 horizontal CNC lathe is a brand new design based on the progressive technology research and development ideas, as also combining with the years of our experience in designing horizontal CNC lathes, born to better satisfy users.

The main performance indexes of this product have reached the international advanced level. The product has super high precision and stability, also high rigidity structure of large cutting feed, so as to provide the customers high efficiency, high stability, sterling world-class machine cost-effectively.

Modularized developing ideas and integrated design concept build platform-oriented machine. The type of components cut down by forty percent. So that the stability increases and further maintenance easily. Comparing with the same kind of machine tools, Viva Turn 2 obtains larger inner space by its smaller shape so that it can machine larger components.

High Precision
High Efficiency

High Speed
High Rigidity



Technology Upgrades



20% ↑ Spindle Accuracy
12% ↑ Max Speed of Spindle



25% ↑ Rapid Traverse
16% ↑ Positioning Accuracy

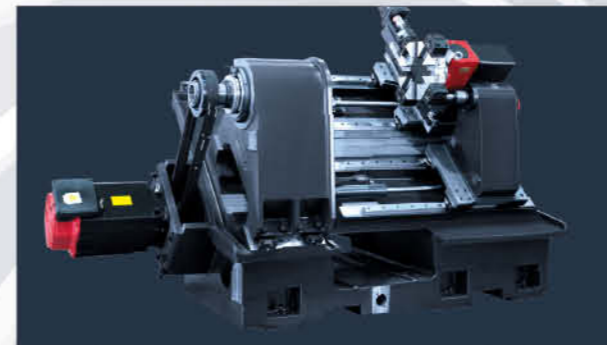

40% ↓ Component Kind
9% ↓ Standard Site Area

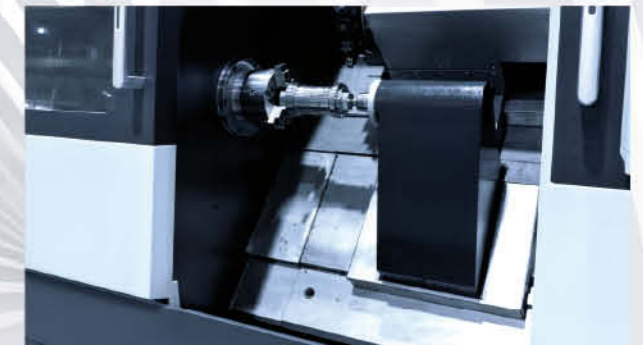

50% ↓ Force of Pulling Door
15% ↓ Distance of Loading

THE FOUR BRANCH COMPANY IN THE WORLD



Application Scope

VIVA TURN 2/4 has extreme high precision, rigidity and high stability. High accuracy, efficiency, flexible and diversified configurations make VIVA TURN 2/4 suit to all kinds materials in any field.



Workpiece: Bicycle Axis of Rotation

Workpiece Material: Aluminium Alloy

Working Field: General Hardware Industry



Workpiece: Bearing Ring

Workpiece Material: GCr15

Working Field: Bearing Industry



Workpiece: Crankshaft

Workpiece Material: Nodular Cast Iron

Working Field: Automobile Industry



Workpiece: Half Shaft

Workpiece Material: 42CrMo

Working Field: Automobile Industry



Workpiece Sample: Valve Guide

Workpiece Material: Copper

Linear Velocity: 30-120m/min

Feed Rate: 0.03-0.2mm/r

Machining Efficiency: 0.93min



Workpiece Sample: Clutch Hub

Workpiece Material: Cast Iron

Linear Velocity: 70-120m/min

Feed Rate: 0.1mm/r

Machining Efficiency: 2.38min



Workpiece Sample: Filter

Workpiece Material: 45 Steel, Stainless Steel

Linear Velocity: 2-150/min

Feed Rate: 0.05- 2mm/r

Machining Efficiency: 16.5min



Workpiece Sample: Hub/Axle

Workpiece Material: Steel

Linear Velocity: 60-180m/min

Feed Rate: 0.1-0.3mm/r

Machining Efficiency: 5.73min



Workpiece: Hub Bearing

Workpiece Material: 20Cr

Working Field: Automobile Industry



Workpiece: Guide Sleeve

Workpiece Material: 40CR, 45 Steel

Working Field: Engineering Machinery



Lathe body: The 45° inclined integral body with reasonable internal rib layout ensures the high precision, good rigidity and small vibration. Side and rear chip removal is available.



Spindle: The integral sleeve spindle is jointly designed with the spindle industry famous manufacturer, with optimized structure size meeting the high rigidity and high revolving speed requirements.

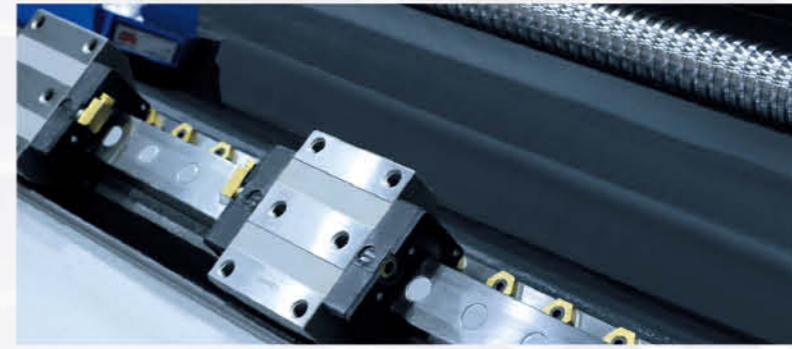

Feed System: Ball screw and ball linear guideway with premium quality promotes machining accuracy and rapid traverse. It allow user to improve machining precision and production efficiency.



Chip Removal System: There are three types of chip removal modes available for selection: left chip removal, right chip removal and rear chip removal. Cooling pump is a large flow high head. The coolant tank and chip conveyor are separated from the main machine to ensure that the accuracy of the machine shall not be affected by cutting heat.

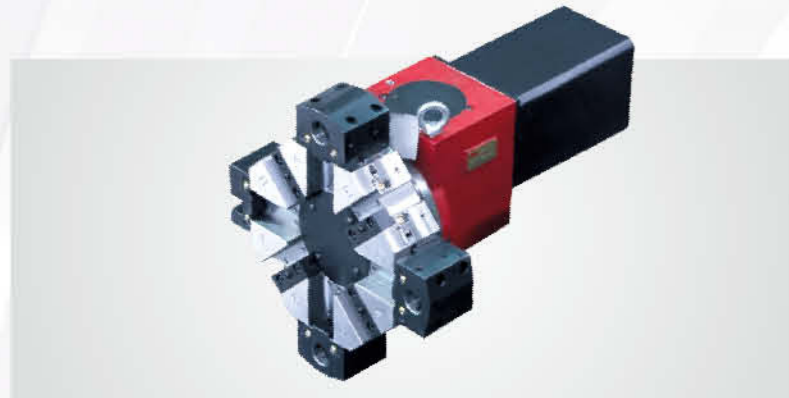

Turret: The standard configuration is equipped with servo turret made by Shenyang No.1 Machine Tool Works having the advantages of good rigidity, reliable locking, fast indexing speed, and high positioning repeatability accuracy. The machine can be equipped with imported power turrets and thereby serve as turning centers.



Tailstock: The machine adopts the integral hydraulic tailstock to insure extreme high rigidity.MT5 tailstock center also offers high thrust tight force work.



Tool Measuring Device(option): Tool setting device could measure the coordinate of tool profile top automatically so that user can take less time in measuring the tool. Tool abrasion will be compensated automatically.



Receiver/Feeder(option): With the rhythm of production, receivers send workpiece to the machining position. Then it picks up a box, spins to the position to get the workpiece and put it into collection box. User can get the workpieces without stopping the machine.

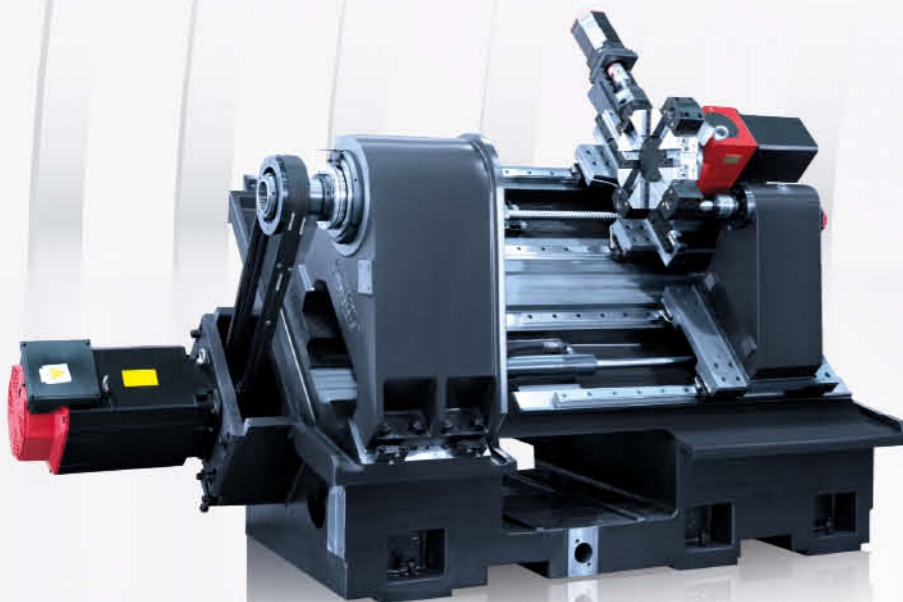

The overall structure of this machine is perfected with the finite element method. With the most reasonable and compact struction, it gets the best rigidity.



Main Specifications

Item	Unit	T2C Series		T2S Series		
		T2C	T2Cm	T2S	T2Sm	
Max Swing Diameter	mm	560	560	560	560	
Max Cutting Length	mm	350/500/1000	500	340/490/990	490	
Max Cutting Diameter	mm	280	280	350	320	
Max Swing Dia. Over Cross Carriage	mm	360	360	360	360	
Spindle Nose		A2-6	A2-6	A2-8	A2-8	
Spindle Hole Diameter	mm	65	65	80	80	
Max Bar Diameter	mm	50	50	66	66	
Spindle Speed Range	r/min	30-4500	30-4500	30-4000	30-4000	
Main Motor Output Power (Continuous/15 minutes)	kw	11/15	11/15	15/18.5	15/18.5	
Spindle Max Output Torque (15 minutes)	N.m	235	235	290	290	
Chuck Diameter	inch	8"	8"	10"	10"	
X/Z Axis Rapid Traverse	m/min	30	30	30	30	
X Axis Travel	mm	200	200	200	200	
Z Axis Travel	mm	410/560/1060	560	410/560/1060	560	
Tailstock Body Travel	mm	-/450/950	450	-/450/950	450	
Tool Size	mm	25×25/ ∅ 32	25×25/ ∅ 40	25×25/ ∅ 40	25×25/ ∅ 40	
Machining Accuracy		IT6	IT6	IT6	IT6	
Positioning Accuracy	X Axis	mm	0.01	0.01	0.01	
	Z Axis	mm	0.01	0.01	0.01	
	C Axis	mm	-	40"	-	40"
Repeatability	X Axis	mm	0.004	0.004	0.004	
	Z Axis	mm	0.005	0.005	0.005	
	C Axis	mm	-	28"	-	28"
Max Load	Disc/Shaft	Kg	200/500	200/500	200/600	200/600
Machine Weight	Machine	Kg	3500	-	3700	-
		Kg	4000	4000	4200	4200
		Kg	4800	-	5000	-
Center Height		mm	1050	1050	1050	1050
Overall Dimensions	L×W×H	mm	2500×1860×1850	-	2500×1860×1850	-
		mm	2750×1860×1850	2750×1860×1850	2750×1860×1850	2750×1860×1850
		mm	3250×1860×1850	-	3250×1860×1850	-

Main Specifications

Item	Unit	T4C Series		T4S Series		
		T4C	T4Cm	T4S	T4Sm	
Max Swing Diameter	mm	720	720	720	720	
Max Cutting Length	mm	500/1000	500/1000	490/990	490/990	
Max Cutting Diameter	mm	500	500	500	500	
Max Swing Dia. Over Saddle	mm	550	550	550	550	
Spindle Nose		A2-8	A2-8	A2-11	A2-11	
Spindle Hole Diameter	mm	80	80	104	104	
Max Bar Diameter	mm	65	65	85	85	
Spindle Speed Range	r/min	30-3000	30-3000	30-3000	30-3000	
Main Motor Output Power (Continuous/15 minutes)	kw	22/30	22/30	22/30	22/30	
Spindle Max Output Torque (15 minutes)	N.m	760	760	760	760	
Chuck Diameter	inch	10"	10"	12"	12"	
X/Z Axis Rapid Traverse	m/min	30/30	30/30	30/30	30/30	
X Axis Travel	mm	280	280	280	280	
Z Axis Travel	mm	570/1070	570/1070	570/1070	570/1070	
Tailstock Body Travel	mm	350/850	350/850	350/850	350/850	
Tool Size	mm	25×25/ ∅ 40	25×25/ ∅ 40	25×25/ ∅ 40	25×25/ ∅ 40	
Machining Accuracy		IT6	IT6	IT6	IT6	
Positioning Accuracy	X Axis	mm	0.01	0.01	0.01	
	Z Axis	mm	0.015	0.015	0.015	
	C Axis	mm	-	48"	-	48"
Repeatability	X Axis	mm	0.005	0.005	0.005	
	Z Axis	mm	0.007	0.007	0.007	
	C Axis	mm	-	24"	-	24"
Max Load	Disc/Shaft	Kg	200/600	200/600	200/800	200/800
Machine Weight	Machine	Kg	5500	5500	5500	5500
		Kg	7500	7500	7500	7500
Center Height		mm	1043.5	1043.5	1043.5	1043.5
Overall Dimensions	L×W×H	mm	3570×2140×2150	3570×2140×2150	3570×2140×2150	3570×2140×2150
		mm	4170×2140×2150	4170×2140×2150	4170×2140×2150	4170×2140×2150

Standard & Option

● Standard ○ Option – No

		T2C Reingistic (Only 350)	T2C Technicality	T2C Advance (No 350)	T2S Technicality	T2S Advance (No 350)
Servo Control	FANUC Oi-Mate System	●	●	–	●	–
	FANUC Oi-TD System	–	–	●	–	●
Chuck System	Solid Chuck	●	–	–	–	–
	Hollow Chuck	–	●	●	●	●
	Tailstock	–	● (No 350)	●	● (No 350)	●
Feed System	Sleeve Spindle	●	●	●	●	●
	Encoder	●	●	●	●	●
	Imported Bearing	●	●	●	●	●
	Taiwanese Screw	●	●	–	●	–
	Taiwanese Guideway	●	●	–	●	–
	Imported Screw	–	–	●	–	●
	Imported Guideway	–	–	●	–	●
Machining System	8 - Position Turret	●	●	●	●	●
	Power Turret	–	○	○	○	○
Auxiliary Machining System	Water Tank	●	●	●	●	●
	Chip Removal	–	●	●	●	●
	Hydraulic & Lubrication System	●	●	●	●	●
Automatic System	Bar Feeder	○	○	○	○	○
	Bar Receiver	○	○	○	○	○
	Tool Measuring Device	○	○	○	○	○
Safety System	Foot Switch	●	●	●	●	●
	Alarm Light	●	●	●	●	●
	Door Safety Lock	●	●	●	●	●

Standard & Option

● Standard ○ Option – No

		T4C Technicality	T4C Advance	T4S Advance
Servo Control	FANUC Oi-Mate System	●	–	–
	FANUC Oi-TD System	–	●	●
Chuck System	Solid Chuck	●	●	●
	Hollow Chuck	–	–	–
	Tailstock	●	●	●
Feed System	Sleeve Spindle	●	●	●
	Encoder	●	●	●
	Imported Bearing	●	●	●
	Taiwanese Screw	●	–	–
	Taiwanese Guideway	●	–	–
	Imported Screw	–	●	●
	Imported Guideway	–	●	●
Machining System	12 - Position Turret	●	●	●
	Power Turret	–	○	○
Auxiliary Machining System	Water Tank	●	●	●
	Chip Removal	●	●	●
	Hydraulic & Lubrication System	●	●	●
Automatic System	Bar Feeder	○	○	○
	Bar Receiver	○	○	○
	Tool Measuring Device	○	○	○
Safety System	Foot Switch	●	●	●
	Alarm Light	●	●	●
	Door Safety Lock	●	●	●